



# Crown Race Setting System **CRS-15**

**Park Tool Co.** 6 Long Lake Rd. St. Paul, MN 55115 (USA) [www.parktool.com](http://www.parktool.com)

## **Introduction:**

The traditional way to “set” the headset crown race on the fork was to slam it on with a large pipe or slide hammer. The CRS-15 Crown Race Setting System offers a new approach that is safer and more precise. With the CRS-15 a specially-sized aluminum ring protects the bearing surface from a direct hit making it safe and effective for use on almost any crown race.

The CRS-15 Crown Race Setting System includes a specially-sized aluminum ring and one driver tube for installing the crown race used on 1.5” headsets.

## **Instructions:**

1. Clean the crown race and the crown race seat so they are completely free of grease or oil.
2. Place crown race on fork.
3. Place the aluminum ring (#827) on the crown race.
4. Place driver tube (#829A) over aluminum ring and tap down with a ballpeen hammer until the crown race is properly seated.

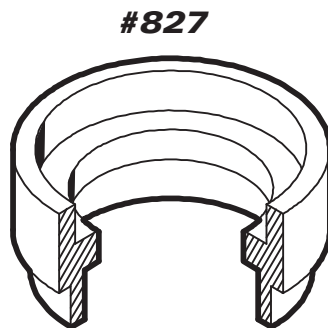

**#827**

**#829A  
Driver  
Tube**

